

THIS DRAWING IS UNPUBLISHED. RELEASED FOR PUBLICATION .19		
COPYRIGHT 19 BY AMP INCORPORATED. ALL RIGHTS RESERVED.		
DESCRIPTION	MATERIAL	FINISH
MODULE ASSEMBLY	EPOXY	COLOR: BLACK
GROMMET	FLUORSILICONE RUBBER	COLOR: BLUE
CONTACT SOCKET	BERYLLIUM COPPER PER QQ-C-533	GOLD PLATE PER MIL-G-45204
RETAINING CLIP	BERYLLIUM COPPER PER QQ-C-533 OR STAINLESS STEEL PER QQ-S-766	NONE
CONTACTS	COPPER ALLOY PER MIL-C-39029/1	GOLD PLATE PER MIL-G-45204
SEALING PLUGS	F.E.P. PER MIL-P-19468	COLOR: BLACK

LOC		DIST		REVISIONS			
DF	AO	P	LTR	DESCRIPTION	DATE	DWN	APVD
		C		REV PER OG3D-0049-00	6-00	CT	DM

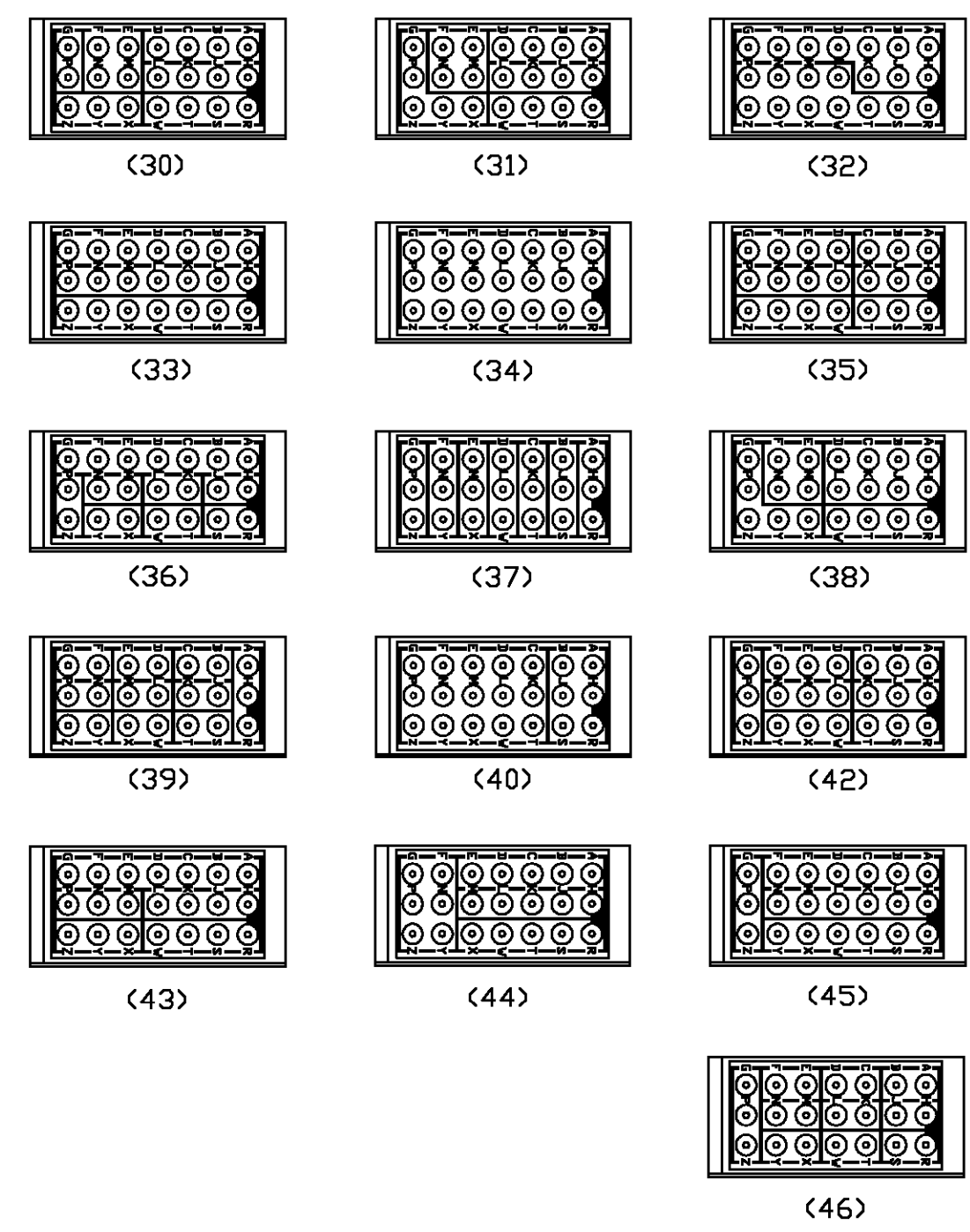
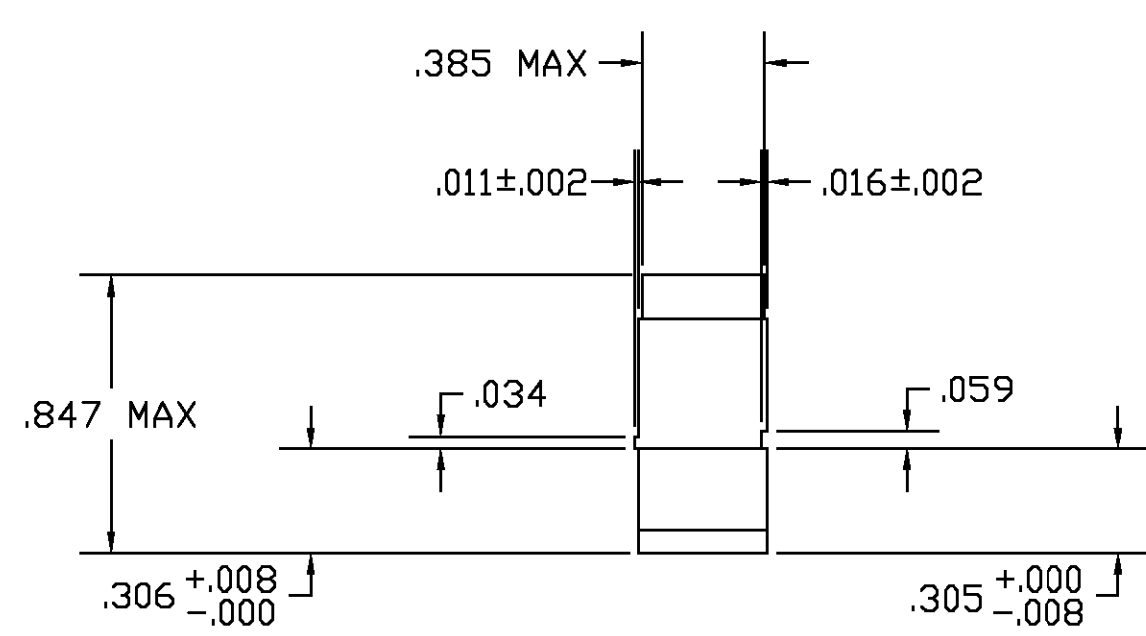
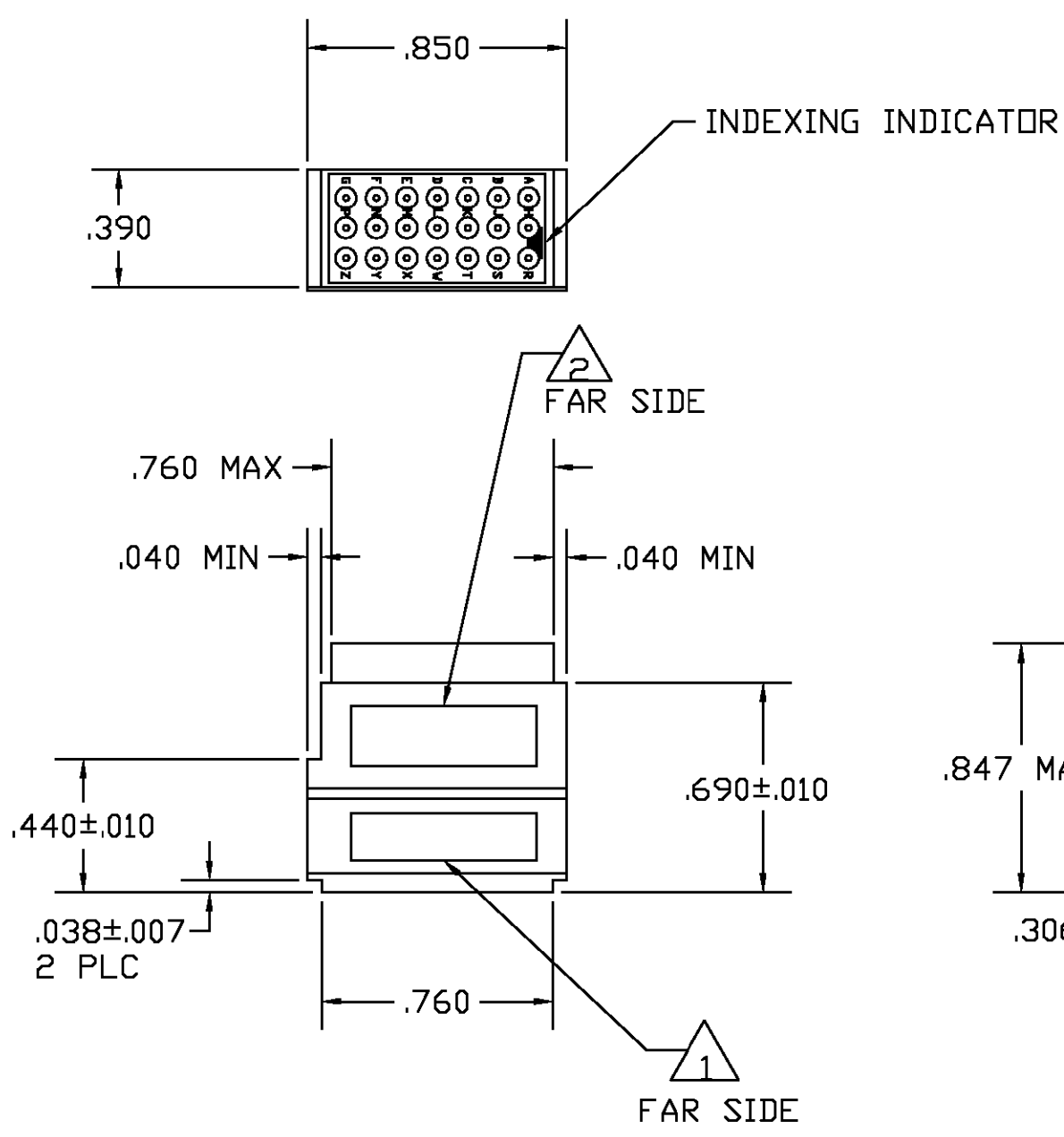

BUSSING ARRANGEMENTS Δ_3

- Δ_3 BUSSING ARRANGEMENT OUTLINE DENOTES INTERNAL ARRANGEMENT OF CONTACT SOCKETS.
- Δ_2 MARK MODULE ASSEMBLY WITH CUSTOMER PART NO., MILITARY PART NO. IF REQUIRED .060 MINIMUM HIGH CHARACTERS AT APPROXIMATE AREA SHOWN.
- Δ_1 MARK MODULE ASSEMBLY WITH "AMP", AMP PART NO. AND DATE CODE .060 MINIMUM HIGH CHARACTERS AT APPROXIMATE AREA SHOWN.

THIS DRAWING IS A CONTROLLED DOCUMENT.		DWN	J. MECK	3-10-93	AMP Incorporated Harrisburg, PA 17105-3608A					
DIMENSIONS INCHES		CHK	R. RYAN	3-31-93						
TOLERANCES UNLESS OTHERWISE SPECIFIED:		APVD	R. RYAN	3-31-93						
0 PLC ± - 1 PLC ± - 2 PLC ± - 3 PLC ± .005 4 PLC ± - ANGLES ± - FINISH -		NAME	R. RYAN							
MATERIAL -		PRODUCT SPEC	MODULE ASSY, FEED-BACK, SIZE 21, TJ							
		APPLICATION SPEC	SIZE	A2	CAGE CODE	00779	DRAWING NO	C-592629	RESTRICTED TO	-
		WEIGHT	CUSTOMER DRAWING		SCALE	2:1	SHEET	1 OF 2	REV	C

THIS DRAWING IS UNPUBLISHED. RELEASED FOR PUBLICATION .19
 © COPYRIGHT 19 BY AMP INCORPORATED. ALL RIGHTS RESERVED.

LOC	DIST	REVISIONS			
P	LTR	DESCRIPTION	DATE	DWN	APVD
DF	AO	SEE SHEET #1	-	-	-

Part No.	46	45	44	43	42	40	39	38	37	36	35	34	33	32	31	30	SEALING PLUG QTY 2	CONTACTS QTY 11	PART NO.
MRTB21D43				X													--	--	4-592629-9
MRTB21D39						X											--	--	4-592629-8
M81714/17-D30															X		X	X	4-592629-7
M81714/17-D45	X																X	X	4-592629-5
M81714/17-D36										X							X	X	4-592629-4
M81714/17-D43				X													X	X	4-592629-3
M81714/17-D42					X												X	X	4-592629-2
M81714/17-D41																	OBSOLETE		4-592629-1
-----				X													--	--	4-592629-0
-----																	SUPERCEDED BY 4-592629-9		3-592629-3
MRTB21D42					X												--	--	3-592629-2
MRTB21D44		X															-----	-----	3-592629-1
MRTB21D37									X								-----	-----	3-592629-0
MRTB21D36										X							-----	-----	2-592629-9
MRTB21D35											X						-----	-----	2-592629-8
MRTB21D34												X					-----	-----	2-592629-7
MRTB21D32														X			-----	-----	2-592629-6
MRTB21D31															X		-----	-----	2-592629-5
MRTB21D30																X	-----	-----	2-592629-4
G383962-1										X							X	X	2-592629-3
-----																	-----	-----	2-592629-2
77A112809-2	X																X	X	2-592629-1
-----																	-----	-----	2-592629-0
M81714/17-D44		X															X	X	1-592629-9
-----																	-----	-----	1-592629-8
M81714/17-D40									X								X	X	1-592629-7
-----																	-----	-----	1-592629-6
M81714/17-D39										X							X	X	1-592629-5
-----																	-----	-----	1-592629-4
M81714/17-D38											X						X	X	1-592629-3
-----																	-----	-----	1-592629-2
M81714/17-D37												X					X	X	1-592629-1
-----																	-----	-----	1-592629-0
M81714/17-D35													X				X	X	592629-9
-----																	-----	-----	592629-8
M81714/17-D34														X			X	X	592629-7
-----																	-----	-----	592629-6
M81714/17-D33															X		X	X	592629-5
-----																	-----	-----	592629-4
M81714/17-D32																X	X	X	592629-3
-----																	-----	-----	592629-2
M81714/17-D31																X	X	X	592629-1

MARKING

THIS DRAWING IS A CONTROLLED DOCUMENT.

DWN	J. MECK	3-10-93	 AMP Incorporated Harrisburg, PA 17105-3608A
CHK	R. RYAN	3-31-93	
APVD	R. RYAN	3-31-93	
PRODUCT SPEC			
APPLICATION SPEC			MODULE ASSY, FEED-BACK, SIZE 21, TJ
SIZE	A2	CAGE CODE 00779	DRAWING NO. C-592629
RESTRICTED TO			
CUSTOMER DRAWING		SCALE 2:1	SHEET 2 OF 2 REV C

DIMENSIONS INCHES	TOLERANCES UNLESS OTHERWISE SPECIFIED
0 PLC	± -
1 PLC	± -
2 PLC	± -
3 PLC	± .005
4 PLC	± -
ANGLES	± -
FINISH	-